



CASE
CONSTRUCTION

ENGINE	
Engine Brand	AL
Engine Model	H40510122
Cylinders	4
Displacement (L)	3.83
Air Intake	Turbocharged intercooled
Fuel Injection	Direct Injection, HPCR
Emission Level	CEV Emission Stage-V
Max Gross Power (kW/ hp) @2200rpm (ISO 14396)	74 / 101
Max Gross Torque (Nm) @1400-1500rpm (ISO 14396)	450
VIBRATION SYSTEM	
Type	Variable Displacement Bi-directional Axial Piston Pump with Electrical Displacement Control
Drive to Vibration Pump	Mechanical Connection
Engine to Pump Ratio	Direct Drive 1:1
Vibration Motor	Fixed displacement mounted on drum
STEERING	
Steering Type	Articulated Hydrostatic Steering
Steering Angle	37° on either side
Turning Radius (inner/outer) (m)	3.42 / 5.83
Drum Oscillation Angle	±15°
ELECTRICAL SYSTEM	
Battery	12 volts, 130 Ah
TYRES	
Tyre Size	23.1-26 8PR
SERVICE CAPACITIES	
Fuel Tank (L)	275
Hydraulic Tank (L)	70
Engine Crank Case (L)	12
Coolant (L)	17.5
Adblue/ DEF tank (L)	24
PROPULSION	
Type	Infinitely variable hydrostatic drive with variable displacement pump

MACHINE SPEED					
Working Speed	5.5 km/hr				
Travel Speed	11.5 km/hr				
Final Drive	High Torque Outboard Planetary				
GRADEABILITY					
Without Drum Drive (%)	31 (17°)				
With Drum Drive (%)	36 (20°)				
Intermittent (%)	40 (22°)				
OPERATING DATA					
	1107NX / NX PLUS	1107NX-D / NX-D PLUS	1107NX-PD / NX-PD PLUS		
Operating Weight (kg)	11100 / 11550	11210 / 11630	12250 / 12940		
Front Axle Load (kg)	5850 / 6250	5910 / 6310	7180 / 7620		
Rear Axle Load (kg)	5250 / 5300	5300 / 5320	5370 / 5320		
Static Linear Load Front (kg/cm)	27.2 / 29.1	27.5 / 29.3	-		
VIBRATION SYSTEM					
	1107NX / NX PLUS		1107NX-D / NX-D PLUS		1107NX-PD / NX-PD PLUS
Vibration Stages	1st	2nd	1st	2nd	1st
Frequency (Hz)	31	34	31	34	31
Amplitude (mm)	2.0 / 1.8	0.9 / 0.8	2.0 / 1.8	0.9 / 0.8	1.4 / 1.3
Centrifugal Forces (kN)	263	145	263	145	263
Max Applied Force (kN)	321 / 325	203 / 207	321 / 325	203 / 207	333 / 338
DIMENSIONS					
A - Horizontal Distance From Drum Center to Tyre Center (m)	3.003				
B - Overall Width of Machine (m)	2.324				
C - Rear Overhang (m)	1.562				
D1 - Diameter of Rear Tyres (m)	1.380				
D2 - Diameter of Drum (m)	1.5				
H - Overall Height of Machine - without / with Transport condition (m)	3.239 / 2.915				
K - Ground Clearance (m)	0.382				
L - Overall Length of Machine (m)	5.508				
O - Side Overhang (m)	0.087				
S - Drum Shell Thickness	STD - 25 mm, PLUS - 32 mm				
W - Overall Width of Drum (m)	2.150				
E1 - Rear Departure Angle (degree)	36				
E2 - Front Departure Angle (degree)	35				

STANDARD EQUIPMENT	
Tilttable Canopy & Sunroof, Auto Idle Feature, 2 Frequency / 2 Amplitude, 2 Front / 2 Rear Working Lights, 2 Side View Mirrors, HSRP Plate, Vibration Cutoff on FNR Lever, Horn, Operator Manual, 1 Steering Wheel	
OPTIONAL EQUIPMENT	
2 Side Work Lamps, Additional Rear Scraper for Drum	

*Consider operator weight ballasting and total weight of machine.

ROPS - Rollover Protection Structure
FOPS - Falling Object Protection Structure
ROPS FOPS - Certified by Government Agency

*T&C apply

CIN: U29240DL1998PTC344616
CASE NEW HOLLAND CONSTRUCTION EQUIPMENT (INDIA) PRIVATE LIMITED
Level-4, Rectangle-1, D-4, District Center, Commercial Complex, Saket, New Delhi - 110017
Contact No.: 011-66544151
Email: caseindia@cnhind.com

CaseCE.com 1800 4199 770

Follow us on @caseceindia

NOTE: Standard and optional fittings can vary according to the demands and specific regulations of each country. The illustrations may include optional rather than standard fittings - consult your CASE dealer. Furthermore, CNH Industrial reserves the right to modify machine specifications without incurring any obligation relating to such changes.

DISCLAIMER: 2.5% variation on parameters may occur and is acceptable by the industry norms.

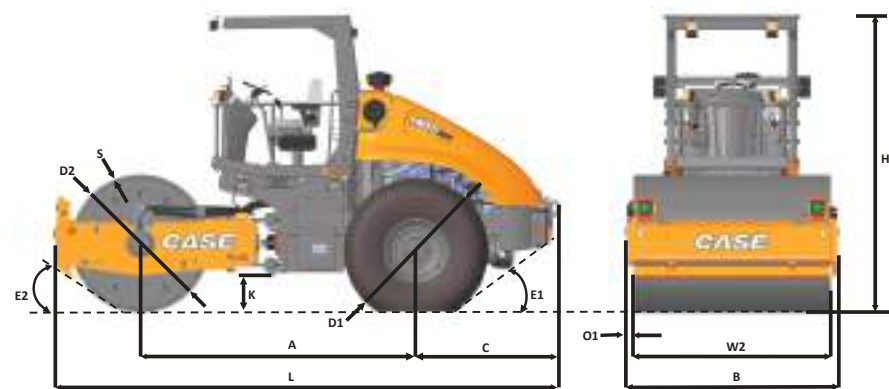

1107NX Brochure Version Dated December 2024

THE NEW ERA IN CONSTRUCTION EQUIPMENT

Presenting
THE ALL-NEW

1107NX CEVS

VIBRATORY COMPACTOR



Eco-Friendly, High-Efficiency
Powerful Engine

myCASE
The New Gen of Telematics

Reliable
Hydraulics



MAIN REASONS

KEY ADVANTAGES OF THE 1107NX SERIES



SUPERIOR ENGINE PERFORMANCE

- Electronic fuel management system enables precise injection control, delivering optimal power output, enhanced handling and reduced fuel consumption
- Smart idling technology cuts fuel usage by approximately 3%



SUPERIOR FUNCTIONALITY

- Dual-mode vibration system with adjustable displacement for diverse compaction needs
- Engineered harmony between speed, movement range and force output delivers industry-leading compaction
- Superior control: $\pm 15^\circ$ oscillation and $\pm 37^\circ$ steering capability creates a tight 3.42m turning circle
- Built-in lighting system for round-the-clock operation
- ROPS and FOPS canopy to increase safety



PROVEN DURABILITY

- Battle-tested 4-way joint system built for extreme conditions
- Premium components sourced from industry leaders: Carraro, Poclain, Danfoss and Bosch
- Modular hood design enables easy transport
- Superior drum thickness options: 25mm (standard) or 32mm (upgrade) for maximum compression
- Optional twin scraper configuration for wet terrain operation
- Reinforced chassis design ensures structural strength



ENHANCED SECURITY MEASURES

- Integrated warning system with sound and light signals
- Automatic engine shutdown protection
- Protected cooling system and fan assembly
- Start prevention in gear
- Secondary brake control on dashboard
- Integrated fuel storage with theft protection



ADAPTABLE CONFIGURATIONS

- Standard 1107NX with rear wheel drive
- 1107 NX-D featuring drum drive for steep inclines and earthwork projects
- 1107 NX-PD incorporating attachable pads and drum drive (factory-installed) for tackling clay, silt, and waste management tasks



ERGONOMIC OPERATOR ENVIRONMENT

- Multi-adjustable swivel seat that includes integrated direction control and vibration shutoff
- Enhanced access points with secure handrails
- Redesigned exhaust placement and streamlined engine covering
- Elevated control station with dual mirrors enables complete visibility and thermal protection
- Vibration-dampened operator platform
- Easy-reach power disconnect



SIMPLIFIED UPKEEP AND REDUCED MAINTENANCE COSTS

- Enhanced locking mechanism
- Ground-level access to core systems
- Floor-height filling points for fuel, hydraulics, and emissions fluid
- Built-in diagnostic port under the dashboard
- Real-time error monitoring with display alerts
- Convenient emissions system access at the rear
- Updated cooling system for extended engine life
- Auto-tensioner system for fan belt that reduces service intervals
- Protected coolant reservoir



MODERNIZED CONTROL INTERFACE

- Anti-glare display system
- Integrated 12V power outlet
- Interactive diagnostic display with menu navigation
- Emergency shutdown on the main panel



INTELLIGENT CONNECTIVITY

- Built-in my CASE Construction Telematics monitoring system
- Pioneer in compactor telematics integration
- Resource optimization through fleet tracking
- Enhanced security with location monitoring
- Predictive maintenance reduces downtime
- Analytics-driven operations boost efficiency

