

V O L V O

# EC210

Volvo Excavators 20.7t - 21.3t, 137 hp



Volvo Construction Equipment

# The power to perform

Get the most out of your excavator in any application. The EC210 is equipped with a range of features to ensure a superior performance, shift after shift. Designed with Volvo's extensive experience and expertise, this robust machine delivers ultimate productivity and efficient operation in a wide variety of tasks.

## Powerful Fuel-Efficient Engine

The engine is manufactured by Volvo Eicher Commercial Vehicles and customised for Volvo Construction Equipment. It combines advanced technology with robust hydraulics to deliver optimum power and high torque at low RPM. This translates into excellent performance and improved fuel efficiency. The engine offers superior quality, reliability, and durability. It is designed to handle tough conditions, including high altitudes upto 2500 meters and cold temperatures as low as -15° C with an optional cold start kit.



## Positive Hydraulic System

The next-generation hydraulic system seamlessly integrates with the fully electronic control system and advanced ECO mode to optimize engine power, minimize losses and enhance controllability with faster response times.

The electro-hydraulic system with an MCV (Main Control Valve) powered by intelligent technology, precisely manages on-demand flow, ensuring high productivity, powerful digging capabilities, and exceptional fuel efficiency. The electro-hydraulic control offers rapid and smooth machine response for exceptional control and precision and simplified troubleshooting for quicker maintenance and reduced downtime.

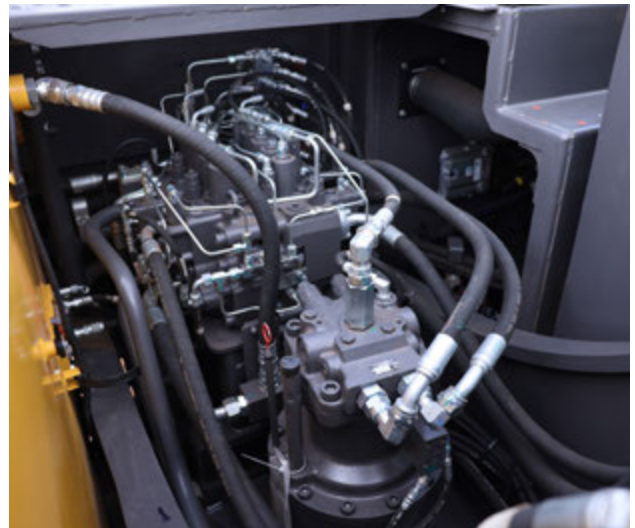

## Cabin

The EC210 is equipped with a spacious and safe operator environment offering enhanced all-around visibility, an adjustable seat and ergonomic controls. The improved cab interior features

a new I-ECU monitor that displays a range of information for efficient operation. This ergonomic design minimizes stress and fatigue, promoting safety and maximizing productivity.



# Efficiency that lasts

The Volvo EC210 is a versatile machine that ensures enhanced profitability. It has Volvo's intelligent ECO mode that lowers fuel consumption, offers best-in-class fuel efficiency and reduces operating costs. The durable design guarantees a long service life to get the most out of your machine.

## Efficient work modes

The EC210 is equipped with unique 10 working modes for effective cycle time and optimum fuel efficiency. Operators can select at hand the best mode to suit the application from Idle (I), Fine (F), General (G), and Heavy (H) mode. Choose the correct mode according to the working conditions for added precision and improved fuel efficiency. Volvo's innovative ECO mode helps maximize fuel efficiency without sacrificing performance.



## Easy to service

The EC210 ensures that servicing is safe, quick and easy. Featuring Grouped Filters, ground level service access, anti slip plates and centralized lubrication points. Efficient service intervals enhance machine availability and increase uptime for maximum productivity.

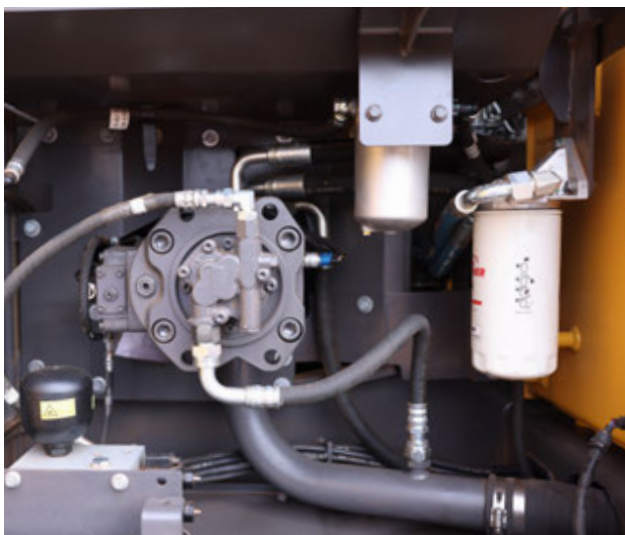

## Instrument Panel - IECU

The all-new, color LCD monitor keeps you informed with vital machine data. Track fuel consumption in real-time, stay ahead with service interval alerts, and diagnose issues quickly with on-screen error codes. The large, anti-glare screen tilts for optimal viewing, making it easy to navigate all the information you need. Easily select working modes and adjust response settings for a truly user-friendly experience.

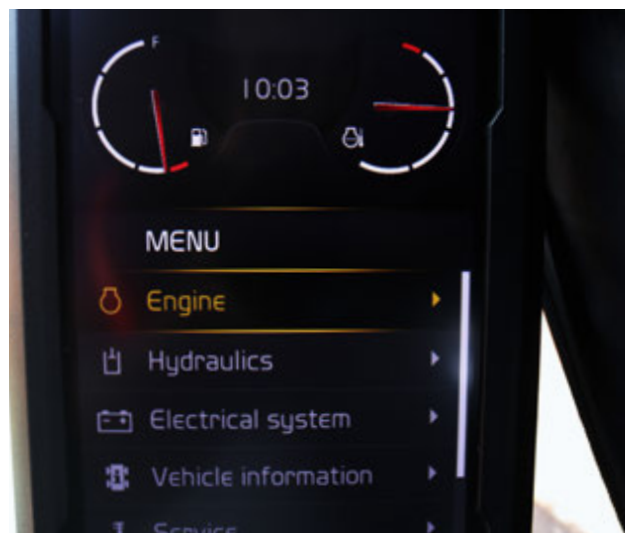

## Genuine Volvo Parts

Volvo Parts are extensively tested and approved because every part is vital for uptime and performance. Only by using Genuine Volvo Parts, you can be sure that your machine retains the renowned Volvo quality.



# Safety

Safety is one of our core value and it is an important part of our product design that ensures safe environment for operator as well as people around.



**Boom Accumulator**  
For the safe lowering of boom in the event of power loss.



**Anti-skid Platform**  
For safety of operators and technicians

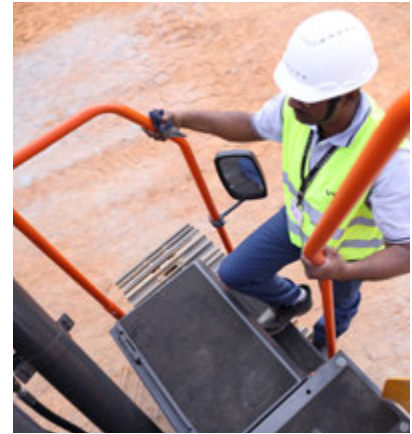

**Side access**  
New improved coloured 3-point side access enhances safety and ease to access.

# Attachment Management System

Make sure you are ready to tackle any job. Volvo CE offers a comprehensive range of attachments that let you handle a wide variety of tasks. The EC210 can be fitted with a selection of buckets and breakers that work in harmony with the machine to ensure optimal performance and profitability in any application.

## Unmatched Versatility and Power

The EC210 boasts of an advanced hydraulic system designed for maximum productivity and attachment compatibility. It allows you to pre-set and adjust hydraulic flow for up to 20 different attachments. Choose between one or two pump flow options to optimize fuel consumption and performance based on your jobsite needs.

## Volvo Hydraulic Quick Coupler

Quick Coupler manufactured by the world's leading authority on pin grabber quick coupler technology. The patented Automatic Blocking System (ABS) prevents the accidental release of an attachment. In the unlikely event of a hydraulic failure or operator error, buckets cannot be dropped or swung dangerously on the front pin. The variable pin centre design allows you to easily pick up and swap the widest range of OEM attachments at your jobsite.



## Telematics system

CareTrack is the Volvo Construction Equipment telematics system that gives you access to a wide range of machine monitoring information designed to save you time and money. With CareTrack you can reduce fuel costs, optimize machine and operator performance and proactively manage service and maintenance to maximize uptime. Stay connected to your machines via remote monitoring and experience new levels of control and efficiency.



### Service schedule

Engine oil and filter, replacing	500 Hrs
Fuel filters, replacing	500 Hrs
Swing gearbox oil, replacing	1000 Hrs
Hydraulic oil servo filter, replacing	1000 Hrs
Hydraulic oil return filter, replacing	2000 Hrs

### Low maintenance cost

- ₹ Lower Engine Maintenance Cost
- ₹ 20% reduced Engine oil and Hydraulic Oil Refill volume
- ₹ Extended oil & Filter change interval (500 hours)
- ₹ Maintenance-free batteries

## Optional auxiliary piping

The Volvo-designed hydraulic breaker / shear piping and quick coupler piping option provides optimum flow to the hydraulic attachments. State-of-the-art auxiliary lines allow the correct flow and pressure for special attachments.

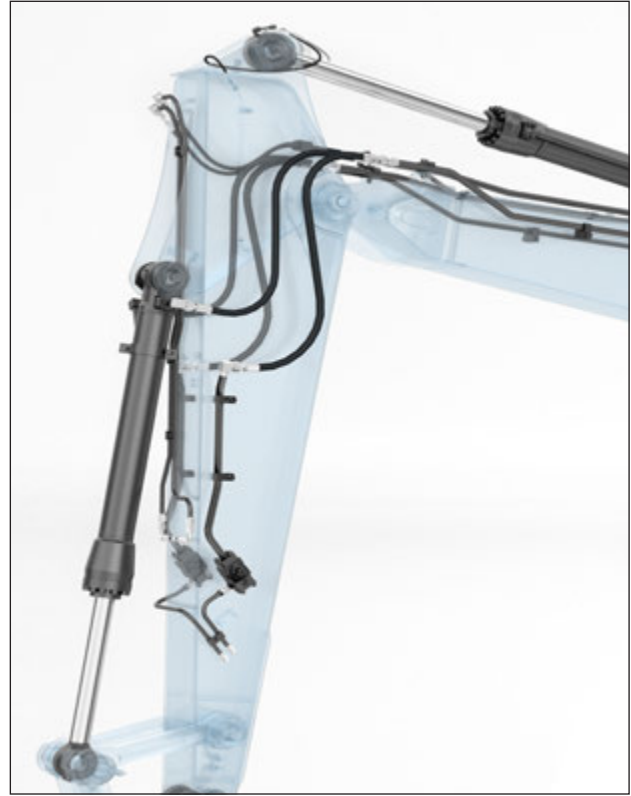

### Standard & Optional Equipment\*

Standard	Optional
Air conditioning	Safety Net
Auto Idle	Cold Start kit
Delay Engine Shut Down	Coolant Heater
Battery cut-off Switch	Fuel Filler Pump
CareTrack	X1 Piping Kit
Boom Accumulator	Beacon Lights
Additional Spool for Breaker	CLS, AFSS
Hand Rail on front & rear of Cab	Rear view Camera
	Quick Coupler

\*Standard and optional items may vary. Consult your Volvo dealer for details.

# New Volvo EC210, E-Series Electronics and Features & Benefits

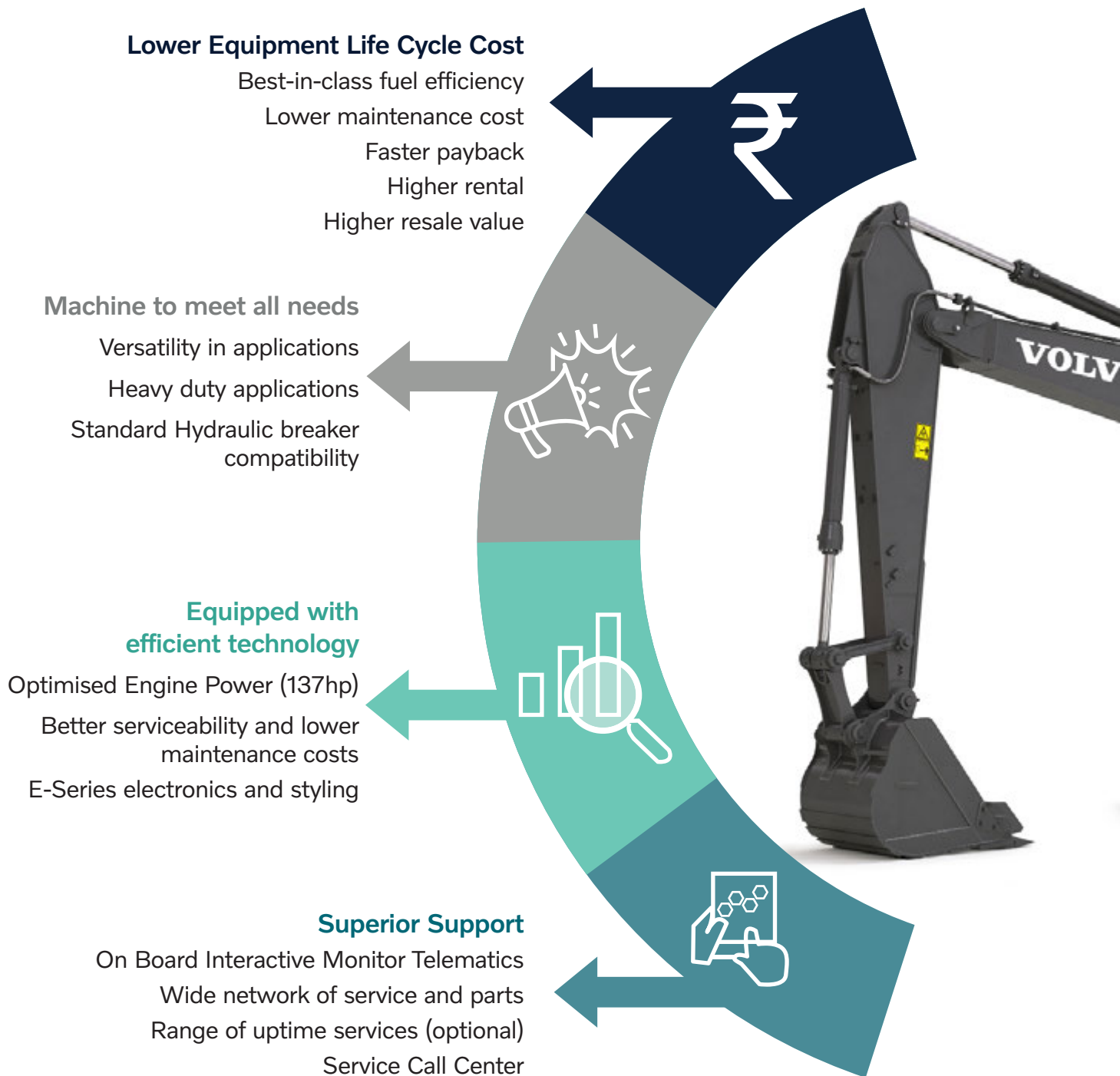

# Styling with improved efficiency.

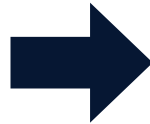

**VECV 494 – T3 Electronic Engine**  
made in India with delay engine shut  
down as standard feature.

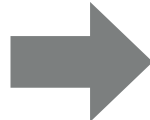

**Higher Fuel Efficiency and  
Lower Maintenance Cost**



**Versatile Machine: Double Acting  
x1 Spool – Standard Fitment**



**10 Efficient Work Modes**



**Posicon Hydraulics –  
Fuel saving and superior  
performance to meet required  
power**

# Versatile Applications



Stone Quarry



Sand Mining



Road Construction



Drill Attachment



Rock Breaker

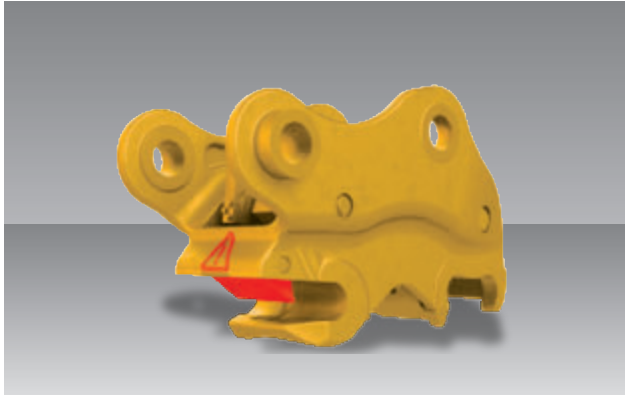

Powerlatch Coupler

# Volvo EC210 in detail

## Engine

The engine, which provide excellent performance, is equipped with four cylinder, electronic-controlled high pressure fuel injectors, internal EGR, in-line waste gate turbo charger, air-to-air intercooler and water cooled diesel engine type.

Engine	VECV	E494-Tier 3
Max. power at	r/min	2000
Gross, ISO 14396/SAEJ1995	hp	137
Max. torque	Nm	520
at engine speed	r/min	1600
No. of cylinders		4
Bore	mm	100
Stroke	mm	120

## Electrical System

High-capacity electrical system that is well protected. Waterproof double-lock harness plugs are used to secure corrosion-free connections. The main relays and solenoid valves are shielded to prevent damage. The master switch is standard.

Voltage	V	24
Batteries	V	2 x 12
Battery Capacity	Ah	100
Alternator	V/Ah	24/75
Start Motor	V - kW	24-5.2

## Swing System

The swing system uses an axial piston motors, driving a planetary gearbox for maximum torque. An automatic holding brake and antirebound valve are standard.

Max. slew speed	r/min	11.5
Max. slew torque	kNm	76.5

## Travel System

Each track is powered by an automatic two-speed shift travel motor. The track brakes are multi-disc, spring-applied and hydraulic released. The travel motor, brake and planetary gears are well protected within the track frame.

Max. drawbar pull	kN	174
Max. travel speed (low)	km/h	3.3
Max. travel speed (high)	km/h	5.5
Gradeability	°	35

## Undercarriage

The undercarriage has a robust X-shaped frame. Greased and sealed track chains are standard.

Track shoe		2 x 46
Link pitch	mm	190
Shoe width, triple grouser	mm	600
Bottom rollers		2 x 7
Top roller		2 x 2

## Positive Hydraulic System

The new electro-hydraulic system and new MCV (main control valve) use intelligent technology to control on-demand flow for high productivity, high-digging capacity and excellent fuel efficiency. The following important functions are included in the system:

**Summation system:** Combines the flow of both hydraulic pumps to ensure quick cycle times and high productivity.

**Boom priority:** Gives priority to the boom operation for faster raising when loading or performing deep excavations.

**Arm priority:** Gives priority to the arm operation for faster cycle times in leveling and for increased bucket filling when digging.

**Swing priority:** Gives priority to swing functions for faster simultaneous operations.

**Regeneration system:** Prevents cavitation and provides flow to other movements during simultaneous operations for maximum productivity.

## 2 x Variable displacement axial piston pumps

Maximum flow	l/min	2 x 200
--------------	-------	---------

## Gear pump

Maximum flow	l/min	1 x 20
--------------	-------	--------

## Relief valve setting pressure

Implement	MPa	32.4
Travel circuit	MPa	32.4
Slew circuit	MPa	27.9
Pilot circuit	Mpa	3.9

## Hydraulic cylinders

Mono boom		2
Bore x Stroke	ø x mm	125 x 1235
Arm		1
Bore x Stroke	ø x mm	135 x 1540
Bucket		1
Bore x Stroke	ø x mm	115 x 1065

## Service Refill

Fuel tank	ltr	360
Hydraulic system, total	ltr	240
Hydraulic tank	ltr	140
Engine oil	ltr	15
Engine coolant	ltr	18
Slew reduction unit	ltr	5
Travel reduction unit	ltr	2 x 3.5

## Cab

The operator's cab has easy access via a wide door opening. The cab is supported on hydraulic dampening mounts to reduce shock and vibration levels. These along with sound absorbing lining provide low noise levels. The cab has excellent all-round visibility. The front windshield can easily slide up into the ceiling.

## Sound Level

Sound level in cab according to ISO 6396

LpA (tropical)	dB(A)	69
----------------	-------	----

External sound level according to ISO 6395, GB16710-2010

# Specifications

## MACHINE WEIGHTS AND GROUND PRESSURE

(EC210 WITH 5.7 M BOOM, 2.5 M ARM, 1.1 CUM BUCKET AND 3800 KG COUNTERWEIGHT)

Description	Shoe width	Operating weight	Ground pressure	Overall width
Units	mm	kg	kPa	mm
Triple grouser	600	20700	46.1	2800

# Specifications

Bucket Selection Guide						
Bucket type	Capacity	Cutting width	Weight	Teeth	EC210 600 mm shoe, 3800 kg counterweight, 5.7 Boom, 2.5 Arm	
Direct Fit Buckets		m <sup>3</sup>	mm	kg	EA	
	GP	1.1	1380	805	6	B
	HD	0.92	1230	947	5	C
Please consult with your Volvo dealer for the proper match of buckets and attachments to suit the application. The recommendations are given as a guide only, based on typical operation conditions. Bucket capacity based on ISO 7451, heaped material with a 1:1 angle of repose.					Maximum material density D: 2100 kg / m <sup>3</sup> C: 1800 kg / m <sup>3</sup> B: 1500 kg / m <sup>3</sup> A: 1200 kg / m <sup>3</sup>	

## Dimensions

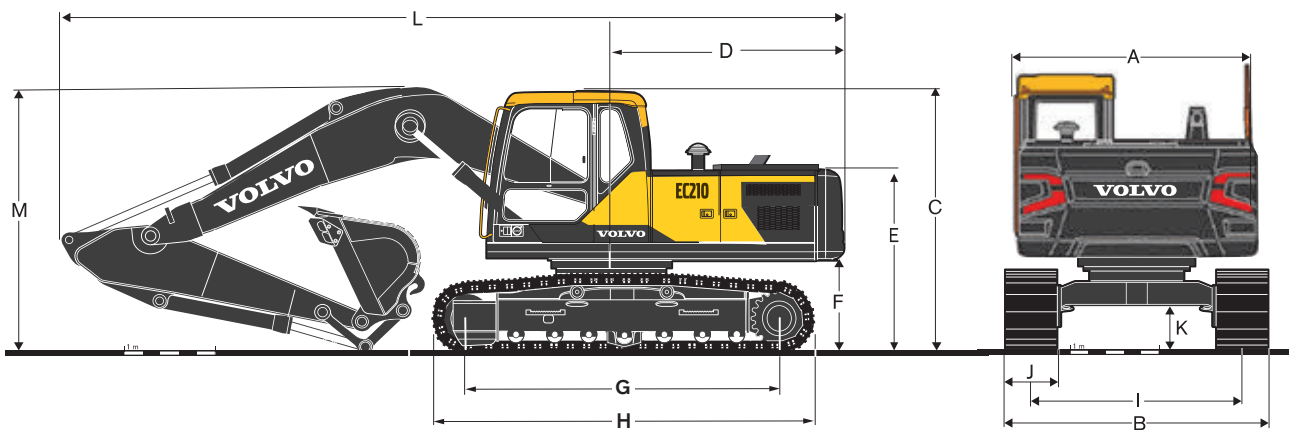

Description	Unit	EC210
Boom	m	5.7
Arm	m	2.5
A Overall width of upper structure	mm	2500
B Overall width	mm	2800
C Overall height of cab	mm	2900
D Tail swing radius	mm	2880
E Overall height of engine hood	mm	2225
F Counterweight clearance*	mm	1005
G Tumbler length	mm	3370
H Track length	mm	4170
I Track gauge	mm	2200
J Shoe width	mm	600
K Min. ground clearance*	mm	450
L Overall length	mm	9780
M Overall height of boom	mm	3083

\* Without shoe grouser

# Dimensions

Description		Unit	Boom	Arm
		m	5.7	2.5
A	Length	mm	5910	3525.0
	Height	mm	1585	860.0
B	Width	mm	670	440.0
	Weight	kg	1851	1006

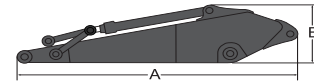
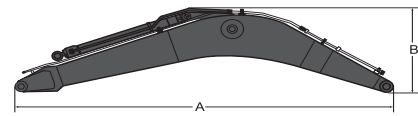

## WORKING RANGES

Description		Unit	
Boom		m	5.7
Arm		m	2.5
A	Max. digging reach	mm	9605
B	Max. digging reach on ground	mm	9435
C	Max. digging depth	mm	6380
D	Max. digging depth (2.44m level)	mm	6163
E	Max. vertical wall digging depth	mm	5095
F	Max. cutting height	mm	9248
G	Max. dumping height	mm	6373
H	Min. front swing radius	mm	3585

## DIGGING FORCES WITH DIRECT FIT ON BUCKET\*

Breakout force bucket	Normal	SAEJ1179	kN	113
	Normal	ISO 6015	kN	126
Tearout force - dipper arm	Normal	SAE J1179	kN	99
	Normal	ISO 6015	kN	101
Rotation angle, bucket			°	175

\*Machine with pin-on bucket

## Working Ranges with Direct fit Bucket

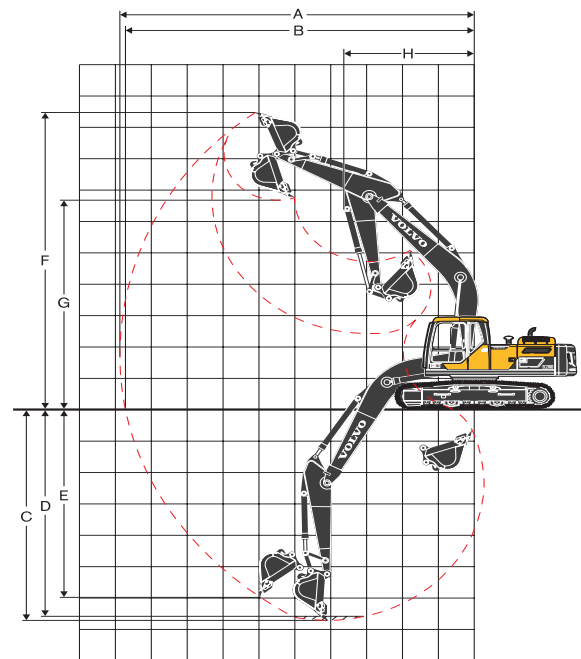

## LIFTING CAPACITY EC210

Lifting capacity at the arm end without bucket. For lifting capacity including bucket, simply subtract actual weight of the direct fit bucket or the bucket with the quick coupler from the following values.

	Lifting hook related to ground level	1.5 m		3.0 m		4.5 m		6.0 m		7.5 m		Max. reach		
		Along UC	Across UC	Along UC	Across UC	Along UC	Across UC	Along UC	Across UC	Along UC	Across UC	Along UC	Across UC	m
Boom: 5.7 m Arm: 2.5 m Shoe: 600 mm CWT: 3800 kg	7.5 m											3360	3360	5.97
	6.0 m							3320	3320			3360	3360	7.14
	4.5 m							3750	3750	3470	3000	3300	3460	7.85
	3.0 m					5900	5900	4450	4310	3770	2890	3540	3300	8.22
	1.5 m					7300	6360	5160	4030	3780	2760	3400	3160	8.30
	0 m					8070	6040	5290	3830	3680	2660	3480	3240	8.11
	-1.5 m	5550	5550	9030	9030	8180	5960	5200	3750	3650	2630	3840	3570	7.61
	-3.0 m	9880	9880	11190	11190	7660	6050	5250	3800			4650	4380	6.74
	-4.5 m			8930	8930	6190	6190					4970	4970	5.32

# VOLVO CE AUTHORIZED DEALER NETWORK

Connect with our largest network of trusted dealerships across Bharat

With 19+ dealerships and 300+ outlets across Bharat, we ensure expert support is always within reach. Backed by 130+ service vehicles and over 800 dedicated service engineers, Volvo CE's authorized dealer network is committed to keeping your operations running smoothly — wherever you are.

## NORTH (INDIA)

**TIME EQUIPMENT PRIVATE LIMITED**  
Plot No. 5G and 5H,  
Additional Industrial Area,  
Main Mathura Road, Faridabad,  
Haryana – 121 006  
Coverage: Delhi-NCR, Haryana,  
Uttarakhand, Uttar Pradesh (including  
NCL Singrauli)  
Dealer Partners: Mr. Sachin Chilana,  
Mr. Vishal Parnami  
Ph #: +91 98738 38862,  
+91 98732 52266  
Email:  
sachin.chilana@timeequipment.co.in,  
vishal.parnami@timeequipment.co.in

**BSES INDIA PRIVATE LIMITED**  
N.H. 8, Ahmedabad Main Road,  
Goverdhan Vilas, Udaipur-313 001.  
Rajasthan  
Coverage: Southern Rajasthan  
Dealer Partner: Mr. Kedar Singh Rathore  
Ph #: +91 98290 41246,  
+91 99283 38553  
Email: ksrathore@bseindia.com,  
dhrurvraj@bseindia.com

**ESDEE SOLUTECH**  
322, Officers Campus Extension, Vaishali  
Nagar, 200 Feet Bypass, Jaipur-302012  
Rajasthan Coverage: Northern Rajasthan  
Dealer Partner: Mr. OP Dawar  
Ph #: +91 96360 76000  
Email: op.dawar@esdeesolutech.net

**PAL INFRASTRUCTURE SOLUTIONS**  
BS Tower, 1st Floor, AKS Colony, Patiala  
Road, Zirakpur, Distt Mohali,  
Punjab-140603, Chandigarh  
Sewa Complex, National Highway,  
Gangyal, Jammu- 180010. Jammu,  
Kashmir (J&K)  
Coverage: STATES of Jammu, Kashmir,  
Himachal Pradesh, Punjab and  
Chandigarh  
Dealer Partner: Mr. Nishant Luthra  
Ph #: +91 98110 42580,  
+91 70870 36541  
Email:  
nishantluthra@luthragroup.net,  
sales.palinfra@luthragroup.net

## EAST (INDIA)

**INFRA EQUIP PVT. LTD.**  
Sahajori GT Road (NH-2), PO Bhiya, PS  
Bawada, Dhanbad - 828 109. Jharkhand  
Coverage: STATE of Jharkhand  
Dealer Partner: Mr. Dinesh Pandey,  
Mr. Naren Pandey  
Ph #: +91 62068 03435,  
+91 70701 92510, +91 70701 92500,  
Email: dineshpandey@infraequip.com,  
npandey@infraequip.com

**POLLUTECH ENGINEERING**  
S, 3/18, Sector, A Zone B, Mancheswar  
Industrial Estate, Bhubaneswar-751010.  
Odisha  
Coverage: STATE of Odisha  
Dealer Partner: Mr. Dilip Kumar Tripathy  
Ph. #: +91 95830 72667;  
+91 77350 65864  
Email: dilip.pollutech.in

**SUCHITA EARTHMOVING SOLUTIONS**  
No. 158, Golden Heights, 6th floor,  
Reliance Trends Building, Near Central  
Mall, G.S Road, Christianbasti, Guwahati -  
781005. Assam  
Coverage: STATES of Assam, Tripura,  
Meghalaya, Nagaland, Mizoram,  
Arunachal Pradesh, and Manipur  
Dealer Partner: Ms. Amita Bhuwalka  
Ph #: +91 99540 89208  
Email:  
amitabhwalka@suchitagroup.com

**SUCHITA MILLENNIUM PROJECTS  
PVT. LTD. (WB)**  
#9, Murlidhar Sen Lane, Kolkata-  
700073. West Bengal  
Coverage: States of West Bengal and  
Sikkim  
Dealer Partner: Mr. Raghupati Bhuwalka  
Ph#: +91 99039 60633, +91 33 2219  
7951, 7952, 3183, +91 99013 70734,  
+91 75960 68773  
Email:  
raghupati@suchitagroup.com

**SUCHITA MILLENNIUM PROJECTS  
PVT. LTD. (BH)**  
Khata -179, KHSERA-285, OPP. SL  
Mishra Petrol Pump, Bashri Dhabalpara,  
Chainpara Post Office, Begampur, PS-  
Bye PASS Thanapatna City, Patna, Bihar  
-800 009.  
Coverage: States of Bihar  
Dealer Partner: Mr. Raghupati Bhuwalka  
Ph #: +91 98013 70734,  
+91 75960 68773  
Email:  
raghupati@suchitagroup.com,  
santoshsingh@suchitagroup.com

## WEST (INDIA)

**DRS EARTHWORK PVT. LTD.**  
C 243, MIDC Road, T T C Industrial Area,  
Pawne, Navi Mumbai,  
Maharashtra - 400 073  
Coverage: Northern Maharashtra  
Dealer Partner: Mr. Divish Sabhlok  
Ph #: +91 98997 93431,  
+91 96252 02621  
Email:  
divish.sabhlok@drsgroupindia.com,  
divishsabhlok14@gmail.com,  
vishal.poria@drsgroupindia.com

**NAVIN INFRA SOLUTIONS PVT. LTD.**  
Plot No. 444 Scheme No. 78, Part-1,  
Phase II, Indore - 452010. Madhya  
Pradesh.  
Coverage: State of Madhya Pradesh  
Dealer Partner: Mr. Navin Bhandari,  
Ms. Seema Bhandari, Mr. Nilesh Bhandari  
Ph#: +91 9993055503, +91 93025  
55002,  
+91 9302155002, +91 9300077300  
Email: navinbhandari@navininfra.com,  
salesco@navininfra.com,  
pushpananddalumar@navininfra.com,  
nileshbhandari@navininfra.com

**SVP MINING TECHNOLOGIES PRIVATE  
LIMITED**  
Ring Road No. 1, Near Sorana Bridge,  
Village Sarona, Post Tatibada, Raipur-  
492 001. Chhattisgarh  
Coverage: State of Chhattisgarh  
Dealer Partner: Mr. Pramod Patwardhan  
Ph#: +91 99703 22222,  
+91 84350 05500  
Email: pramod@svpgrp.net

**TEAM ENGINEERS**  
Karan Samrudhi Survey No.5, Shogini,  
Karan Samrudhi, Nawale Bridge,  
Ambegaon (8)  
Pune - 411 046. Maharashtra  
Coverage: Southern Maharashtra and Goa  
Dealer Partner: Mr. Ajit Bafna, Mr.  
Shridhar Bhat, Mr. Anand Rajore  
Ph #: +919370 145680,  
+91 93701 45660, +91 98220 33202  
Email: ajit@teamengineers.co.in.,  
srb@teamengineers.co.in,  
anand.rajore@teameng.co.in

**WEST INDIA EQUIPMENT'S PVT. LTD.**  
Survey No.: 109/129, Opp. Gokuldham  
Society, Near Ford Service Centre,  
Santhipura-Sanand Highway, Ulariya,  
Ahmedabad-382 210. GUJARAT  
Coverage: STATE of Gujarat, Dadra and  
Nagar Haveli, Daman and Diu  
Dealer Partner: Mr. Jesal Suresh Vora,  
Mr. Aashish Khurana  
Ph #: +91 98256 09097;  
+91 98795 35995  
Email: jesal.vora@gmail.com,  
jesal@westindiaequip.com,  
Khurana.aashish@gmail.com

**SUCHITA EQUIP PVT. LTD.**  
Flat No.: 262/1, NH-8, Highway Road,  
Behind Saat Hanuman Temple,  
Rudra Transport Nagar  
Rajkot. District: Rajkot  
Gujarat - 360 003  
Dealer Partner: Mr. Raghupati Bhuwalka  
Mr. Samar Bals-CEO  
Ph #: +91 99039 60630  
Email: samarbais@suchitagroup.com

## SOUTH (INDIA)

**ADVANCED CONSTRUCTION  
TECHNOLOGIES PVT. LTD**  
No.5/55, Kuthambakkam Village, Post  
Forest Range Road, Chettipadu,  
Poonamallee Taluk, Tiruvallur Dist.,  
Chennai-602 107. Tamil Nadu  
Coverage: State of Tamil Nadu,  
Pondicherry, Andaman Nicobar,  
Lakshadweep Islands  
Dealer Partner:  
Mr. Siddarth Raman  
Ph #: +91 98847 57350  
Email: siddarth.raman@actind.com

**ENCORE HEAVY MACHINERY PRIVATE  
LIMITED**  
#259, 1st Cross, 4th Phase, Peenya  
Industrial Area, Bangalore 560 058.  
Karnataka  
Coverage: State of Karnataka  
Dealer Partner: Mr. H Vinayak Nayak  
Ph#: +91 80 29734009;  
+91 78999 03813  
Email: vinayak@encorece.in

**PACT MACHINES PRIVATE LIMITED**  
Door No. VII/267 A, Malikkampeedika,  
Alangad P.O., Ernakulam District, Aluva -  
683 511. COCHIN, Kerala  
Coverage: STATE of Kerala  
Dealer Partner: Mr. Siddarth Raman  
Ph#: +91 99959 22350  
Email:  
siddarth.raman@pactmachines.com

**RAMANAND POWER SYSTEMS PVT.  
LTD. - (TS)**  
Door No: 8-2-269/3-82, Plot No. 82,  
Road No. 3, Sagar Society, Banjara Hills,  
Hyderabad-500 034. Telangana  
Coverage: State of Telangana  
Dealer Partner: Mr. Rama Rao,  
Mr. Anand Anumolu,  
Mr. Nagarjuna Mandava  
Ph#: +91 98451 50173,  
+91 94920 54224, +91 9990 975051  
Email: sreeram@ramanand.co.in,  
anand@ramanand.co.in,  
nagarjuna@ramanand.co.in

**RAMANAND POWER SYSTEMS PVT.  
LTD. (AP)**  
Door No 40-3-181, First Floor, B-Block,  
Rajeswari Nilayam, KS Ramarao Street,  
Moghalrajapuram, Vijayawada, Andhra  
Pradesh- 520010  
Coverage: State of Andhra Pradesh  
Dealer Partner: Mr. Rama Rao,  
Mr. Anand Anumolu,  
Mr. Nagarjuna Mandava  
Ph#: +91 98451 50173,  
+91 94920 54224, +91 9990 975051  
Email: sreeram@ramanand.co.in,  
anand@ramanand.co.in,  
nagarjuna@ramanand.co.in

## INTERNATIONAL

**A B CONSTRUCTIONS LIMITED**  
Plot No. 22, Rob Super Market (5th  
Floor), Gulshan-2, Gulshan, Dhaka, PO:  
1212, Bangladesh  
Dealer Partner: Mr. Mursalin Ahmad  
Ph#: +880 1711-207295  
Email: mursalin@abcl.com.bd

**DAX ENGINEERING CO. (PVT.) LTD.**  
No 179/7, Wanaguru, Mawatha,  
Hokandara South, Hokandara, Sri Lanka.  
Postal Code-10118  
Dealer Partner: Mr. Wijayasinghe  
Ph#: +94 7142 73900,  
+94 714273920  
Email: wije@daxholdings.lk

**EXPLORE EARTH MOVERS PVT. LTD.**  
Chakupat, Patan Dhoka, Panchakanya  
Bhawan, Patan, Lalitpur, Nepal.  
GPO-44600  
Dealer Partner: Mr. Sushil Shrestha,  
Mr. Udeep Shrestha  
Ph#: +977 985 1107251,  
+977 980 2055155  
Email: sushil@explorentl.com,  
udeep@panchakanya.com

**RIWANG HEAVY EQUIPMENT AND  
SERVICES**  
Riwang Building, Simtokha, Thimphu,  
Post Box 1132, Bhutan  
Dealer Partner: Mr. Rinzy Wangchuk  
Ph #: +97 517111965  
Email: rinzy@riwangs.com

**SOLUTION ENGINEERING LTD.**  
#201/206, Nasirabad Industrial Area,  
Chittagong 4210, Bangladesh  
Dealer Partner: Mr. Rashed Chowdhury  
Ph #: +880 1819312618  
Email  
rashed.chowdhury@sel-pti.com.bd